

STRETCH METAL



www.luxalon.com

LUXALON®

Ceiling Systems

A HunterDouglas® PRODUCT

Luxalon®

Stretch Metal

Striking visual effects

Luxalon® Stretch Metal offers architects contemporary design freedom. With these versatile materials it is easy to create an optical contrast to other surrounding materials. The wide choice of patterns, materials and colours gives every project a unique appearance.

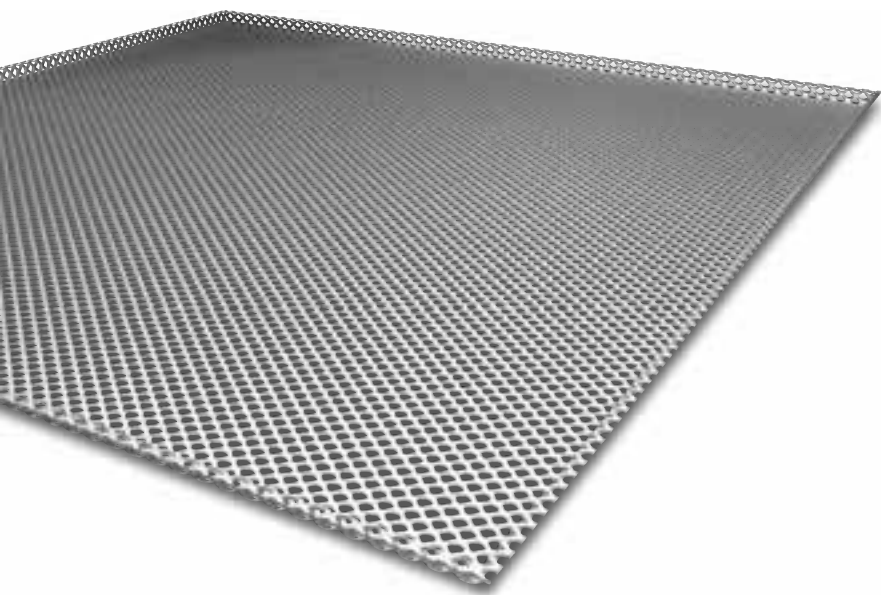

Aesthetic design

Luxalon® Stretch Metal is a versatile architectural design material that creates striking visual effects. It is easy to create unique ceiling designs by variation in mesh types, mesh direction, lighting and colours.

Variation in ceiling design is easy if one keeps in mind that:

- The openness of the ceiling depends on the choice of mesh size and mesh pattern
- A change of mesh direction gives another incidence of light and therefore a different visual look
- Luminaries above the Stretch Metal ceiling gives lighting patterns and shadow effects

LUXALON® _____

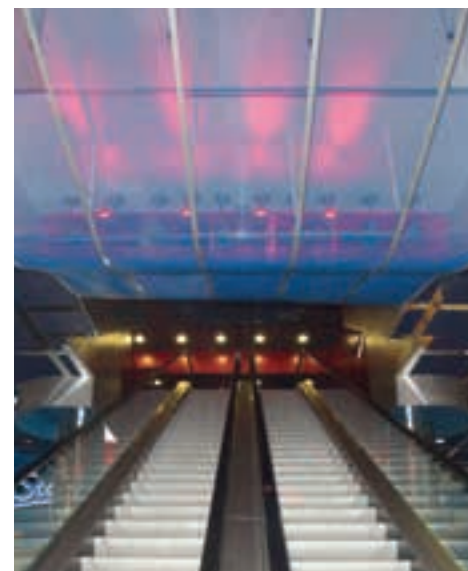





Standard solutions

The standard Stretch Metal ceiling program consists of aluminium and steel tiles and planks.

Tiles

The tiles program consists of modules 600 x 600 Lay-in, 625 x 625 Bandraaster and 1000 x 1000 Bandraaster solutions.



Planks

The planks program consists of a corridor, a Bandraaster and a C-grid solution. These planks are all made to measure with a maximum width of 500 mm and a maximum length of 2800 mm.



Custom design

On special request several project solutions are possible. Custom sizes or shapes can be defined to make unique projects possible.

- Special sized panels
Custom made strengthened profiles make it possible to create wider and longer panels
- Curved panels
Custom made curved profiles create unique concave, convex and undulating shapes



Material

Stretch Metal consists of metal sheet with diamond shaped holes. These holes are created without any waste of material, because the metal sheet is made with a tool that presses and stretches at the same time.

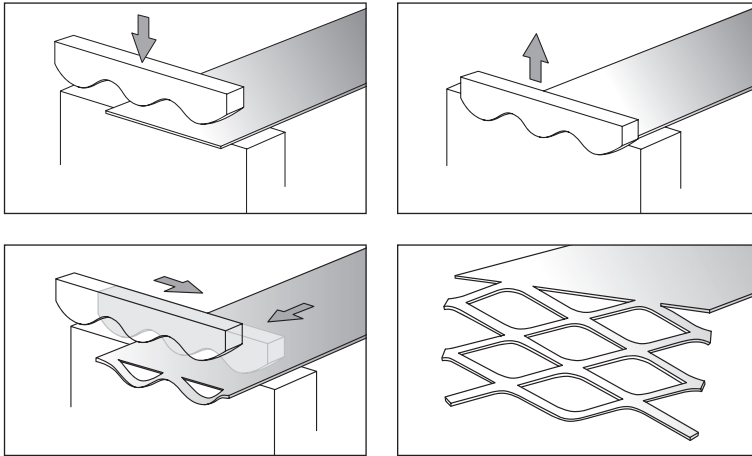

Mesh types:

Standard

The standard mesh type is a square mesh (LS) or a diamond shaped mesh (LD) with a variation in openness of the mesh. The range starts with the smallest LS6/LD6 up to LS16. All mesh types are available in steel, with types LS8 and LS12 also available in aluminium.

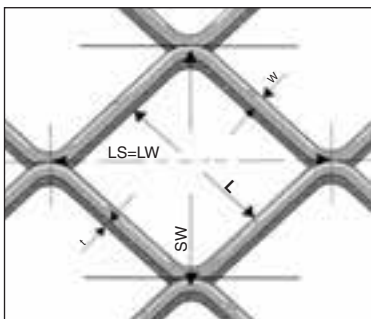

Key

- LS = LW
- LW = Long way of mesh
- SW = Short way of mesh
- W = Strand width
- t = Strand Thickness
- L = Inner size

Standard mesh types:

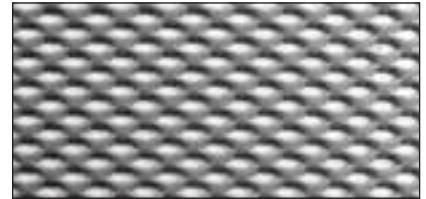

LD6 Fe open area 23%, thickness 1.7 mm

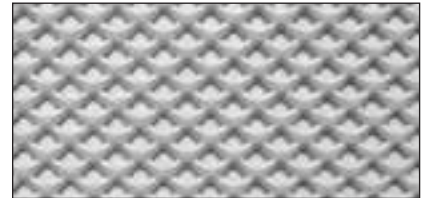

LS6 Fe open area 38%, thickness 1.7 mm



LS8 Fe + Al open area 62%, thickness 1.9 mm



LS10 Fe open area 68%, thickness 2.0 mm



LS12 Fe + Al open area 72%, thickness 2.0 mm



LS16 Fe open area 66%, thickness 2.0 mm

Special

Several other mesh types are available on request depending on technical requirements and availability.

Hexagonal mesh, Round mesh and Ornamental meshes are examples of the possibilities.

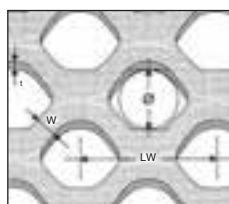
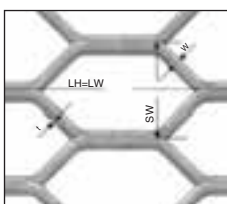

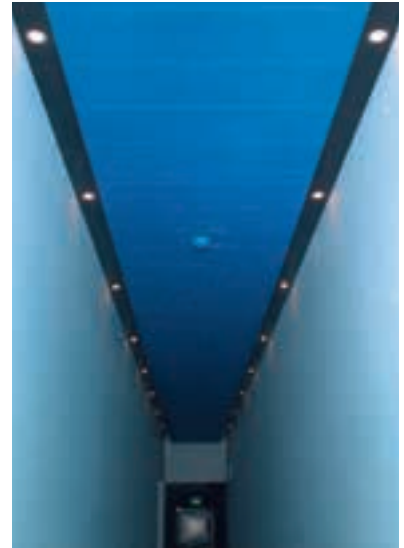

Colours and finishes

There are a large quantity of RAL colours available with a short delivery time. In addition to these colours there are several special metallic colours and chrome in the program. The complete program of panels, grids, Bandraister profiles and edge profiles can be made in one colour for a smooth ceiling.



Acoustics

Using acoustic pads on top of the Stretch Metal panels offers exceptional acoustic performance. The thickness of the pads can be chosen depending on the required acoustical values. The acoustic absorption value can reach α_w 1 with an acoustical pad of 85 mm.

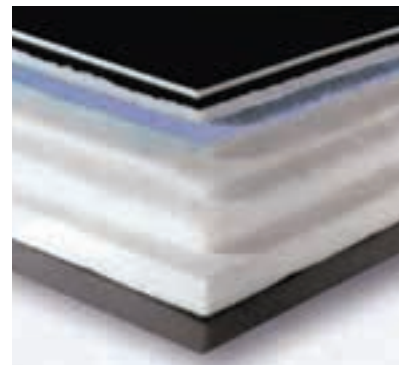
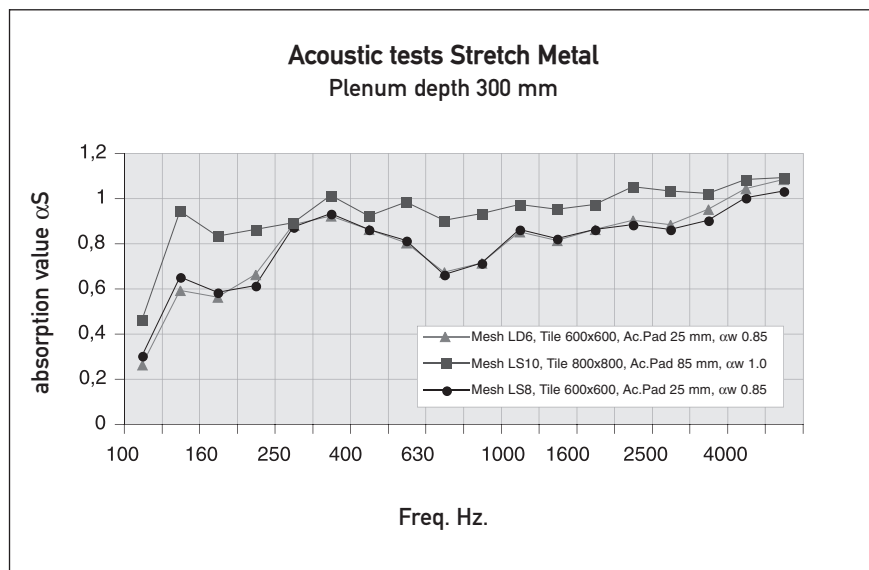



Project Consulting

Luxalon® ceilings are designed with an eye for detail and in order to support our business partners and to provide benefit from the Luxalon® experience, we have our own 'in house' architectural design team providing various technical services.

This Architect Services Group are dedicated to creating ceilings that meet the demands of architects, designers, investors and installers all over the world.



Quality

Our focus on quality control ensures the highest standard of production process, material, machinery and finished product. The superior durability of Hunter Douglas products translates into lower costs during the life cycle of the product due to longer life expectancy and lower maintenance costs. All our company processes are ISO 9001 certified.



100% recyclable



LUXALON®



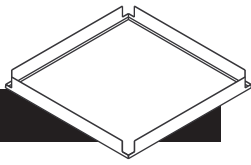

SYSTEM OVERVIEW STRETCH METAL LAY-IN TILES

Short system description

Luxalon® Lay-In tiles are designed to be installed on conventional T-grid systems (T-Bar sizes 15 and 24 mm) or Bandraster system (50-100 mm). By pushing the tile upwards it is easy to gain access to the plenum without the use of special tools.

Practical application areas

Luxalon® Stretch Metal tiles are ideal for solutions where either a high level of acoustic absorption is required or where visual and physical transparency of the ceiling is requested. The systems are also ideal for solutions where regular access into the plenum is required.

Transparency

The tiles can be made from various mesh types. This results in different optical effects if the natural or artificial light comes from the plenum. The physical transparency can also be used for smoke extraction and sprinkler operation in case of fire.

Plenum accessibility

Because each tile has flanges that simply rest on the T-Grid profiles, the access to the plenum is achieved by lifting the tile up into the area above the ceiling.

Acoustics

Excellent sound absorption is obtained with the different mesh types in combination with acoustic pads. Absorption co-efficients of up to $\alpha_w 1$ are achievable.

Mesh types

Tiles are available in a standard square mesh LS or diamond shaped mesh LD with differences in open area. Special meshes are available on request.

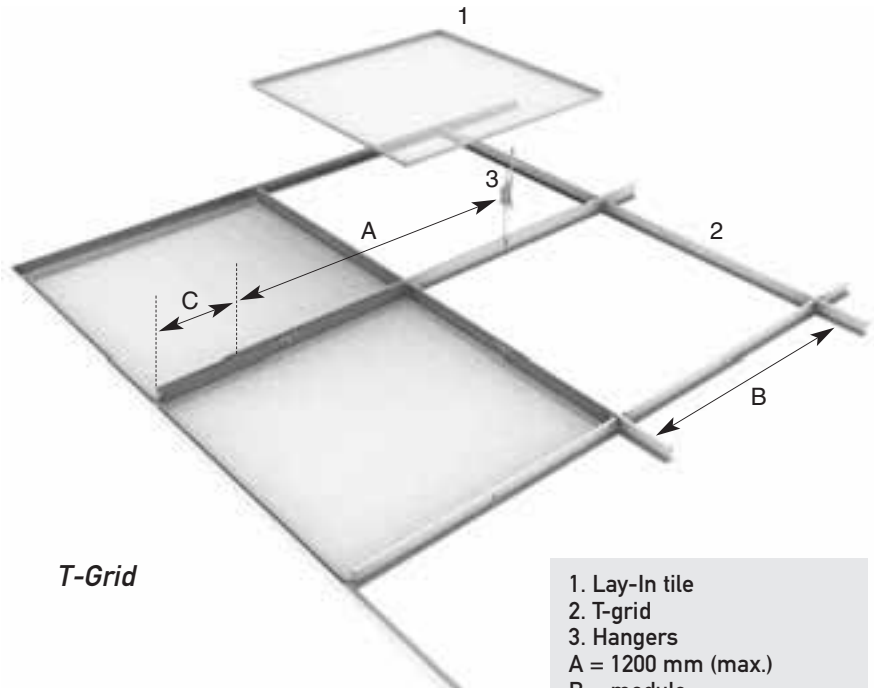

T-Grid

- 1. Lay-In tile
- 2. T-grid
- 3. Hangers
- A = 1200 mm (max.)
- B = module
- C = 250 mm (max.)

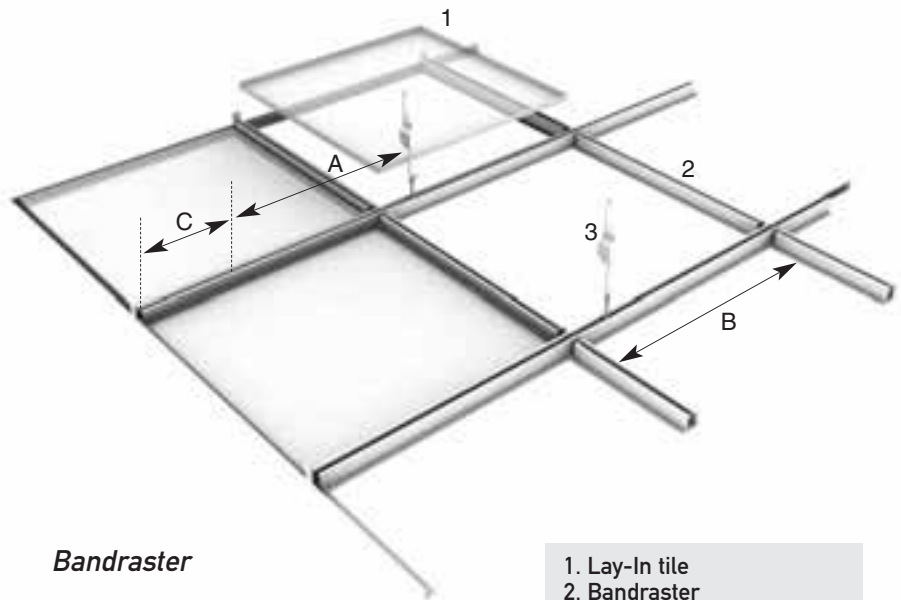

Bandraster

- 1. Lay-In tile
- 2. Bandraster
- 3. Hangers
- A = 1200 mm (max.)
- B = module
- C = 250 mm (max.)

Dimensions

Lay-In Tiles 15/10; 15 mm Grid,
10 mm Reveal

Module in mm
600 x 600

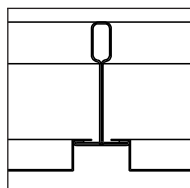

Lay-In Tiles 24/15; 24 mm Grid,
15 mm Reveal

Module in mm
600 x 600

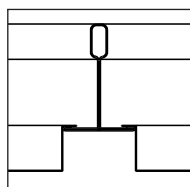

Lay-In Tiles 24/0; 24 mm Grid,
0 mm Reveal

Module in mm
600 x 600

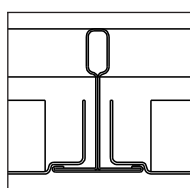

Lay-In Tiles; 50 mm Bandraster,
0 mm Reveal

Module in mm
625 x 625

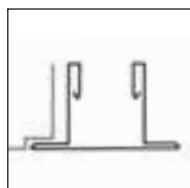

Lay-In Tiles 15/10; 15 mm channel
Grid

Module in mm
600 x 600

*(T-profile with integrated fixing
possibility for partitions)*

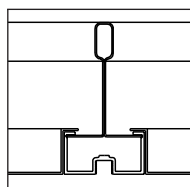

Material Requirement per m²

Components	Unit	600 x 600
Luxalon® Stretch Metal	pcs.	2.78
Grid profile	lm	3.34
Suspension	pcs	0.69

Lay-In Tiles; 100 mm Bandraster

Module in mm
1000 x 1000

(Only steel)

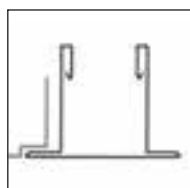

Material Specifications

Base Material

Luxalon® Lay-In tiles module 600 mm and 625 mm are available in steel and aluminium. Luxalon® Lay-In tiles module 1000 mm are available in steel.

Coating

Stretch Metal tiles are all powder coated materials. Durable powder coatings for exterior use are optionally available.

Colour Range

The standard colour range consists of 225 RAL and NCS colours, including chrome. Other special colours are available on request.

Fire Behaviour

Suspended Luxalon® metal ceilings are classified incombustible, and will therefore not contribute to fires. When ceilings need to protect the structural integrity of a building, Luxalon® ceilings offer a wide range of practical solutions with regards to fire resistance and fire stability. Further information is available on request.

LUXALON®

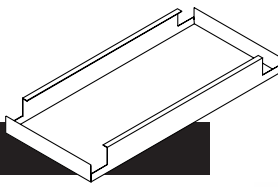

SYSTEM OVERVIEW STRETCH METAL PLANKS

Short system description

Luxalon® steel planks are designed to be installed on conventional C-Grid systems, Bandraster and wall profiles.

The planks can be lifted and easily removed without the aid of tools. The steel panels are recyclable, lightweight and strong.

Practical application areas

Luxalon® Stretch Metal planks are ideal for solutions where either a high level of acoustic absorption is required or where visual and physical transparency of the ceiling is requested. The systems are also ideal for solutions where regular access into the plenum is required.

Transparency

The planks can be made from various mesh types. This results in different optical effects if the natural or artificial light comes from the plenum. The physical transparency can also be used for smoke extraction and sprinkler operation in case of fire.

Acoustic performance

Excellent sound absorption is obtained with the different mesh types in combination with acoustic pads. Absorption co-efficients of up to $\alpha_w 1$ are achievable.

Mesh types

Planks are available in standard mesh types LD6/LS6, LS8 or LS12 with differences in open area. Special meshes are available on request.

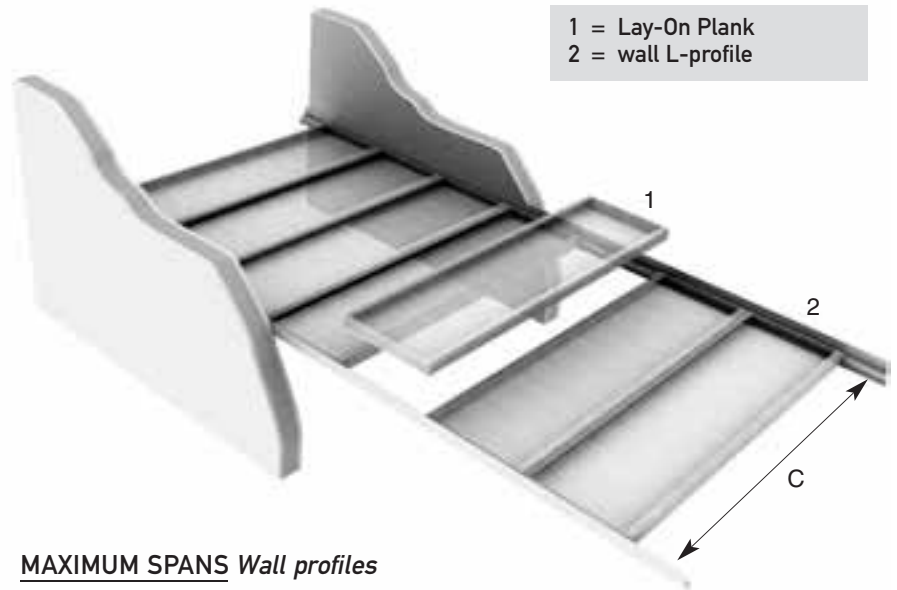

MAXIMUM SPANS *Wall profiles*

Panel type	Panel Span C
Type-I Stretch Metal	1500
Type-II Stretch Metal + profile	2400
Type-III Stretch Metal + C-profile	2800

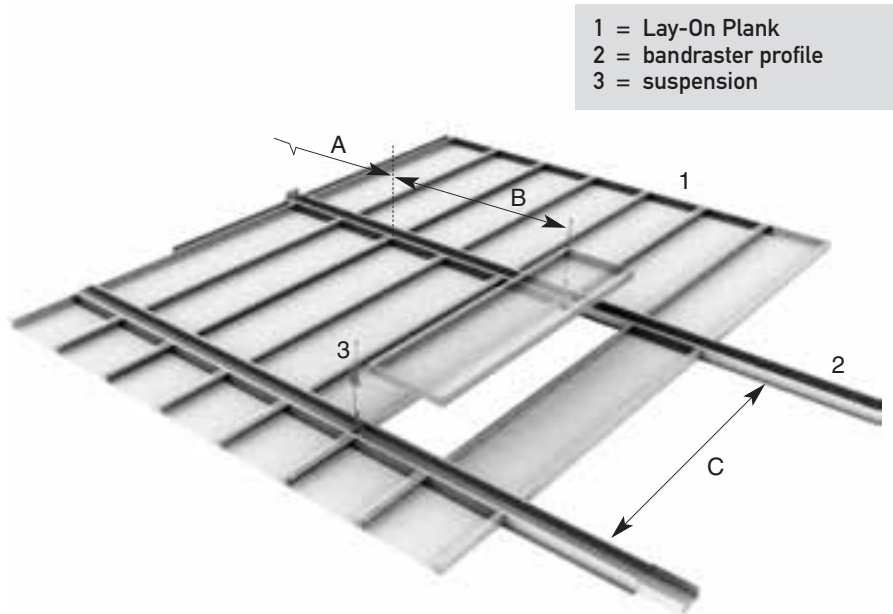

MAXIMUM SPANS *Bandraster*

Panel type	Profile Span		Panel Span C
	A	B	
Type-I Stretch Metal	on request	on request	1500
Type-II Stretch Metal	on request	on request	2400
Type-III Stretch Metal	on request	on request	2800

Lay-On Plank solutions

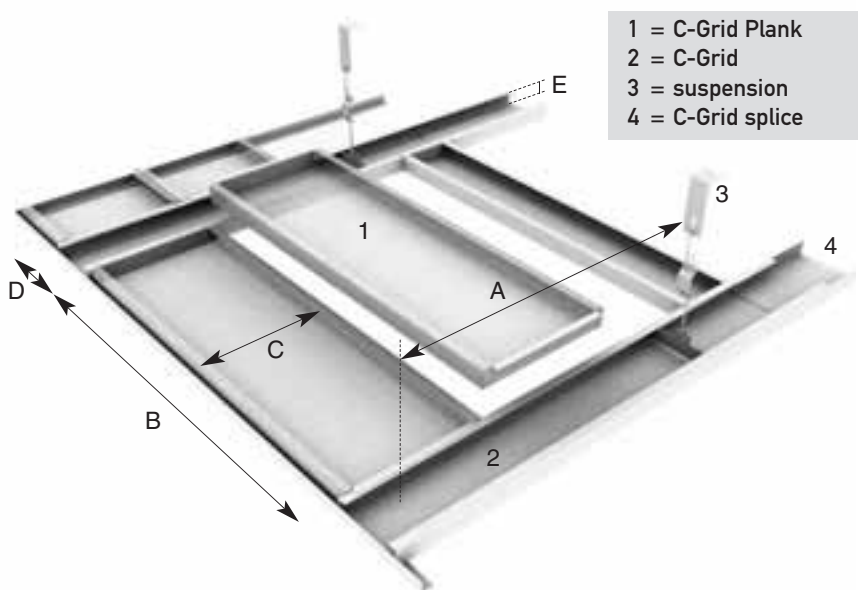
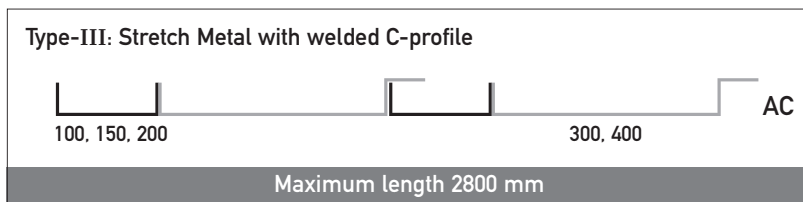
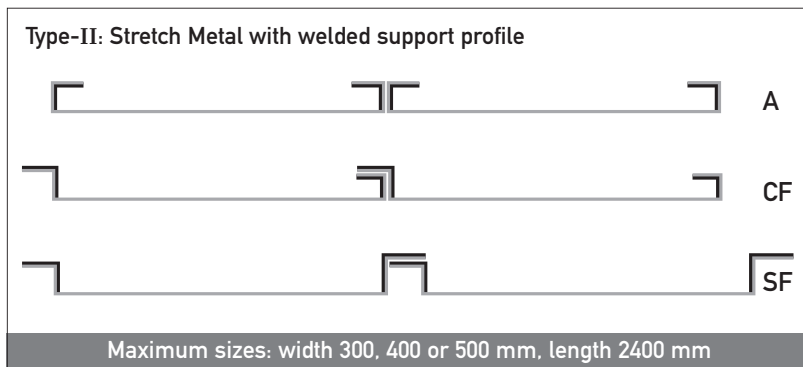
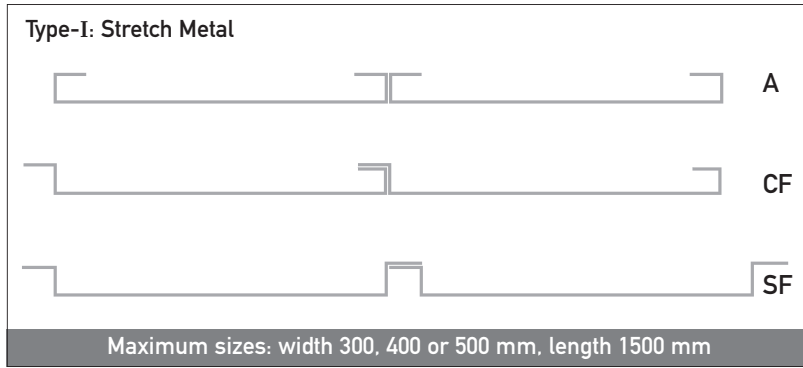

DIMENSIONS C-Grid

Item type	Plank width C	C-Grid width D	C-Grid + plank height E
Steel	300 or 400	120, 150 or 200	40

Material Specifications

Base Material

Luxalon® Stretch Metal planks are available in steel. The Stretch Metal plank (type-I) can be strengthened with a welded support profile inside (type-II) or alongside a welded C-profile (type-III) for larger planks.

Coating

Stretch Metal planks are all powder coated materials. Durable powder coatings for exterior use are optional.

Colour Range

The standard colour range consists of 225 RAL and NCS colours, including chrome. Other special colours are available on request.

Fire Behaviour

Suspended Luxalon® metal ceilings are classified incombustible, and will therefore not contribute to fires. When ceilings need to protect the structural integrity of a building, Luxalon® ceilings offer a wide range of practical solutions with regards to fire resistance and fire stability.

Further information and special executions on request.

MAXIMUM SPANS C-Grid

Panel type	Profile Span A	Panel Span B
Steel	1250	1300

LUXALON®

Austria
Belgium
Bulgaria
CIS
Croatia / Slovenia
Czechia
Denmark
France
Germany
Greece
Hungary
Ireland
Italy
the Netherlands
Norway
Poland
Portugal
Rumania
Slovakia
Spain
Sweden
Switzerland
Turkey
United Kingdom
Africa
Middle East

Further sales offices:

Asia
Australia
Latin America
North America

LUXALON®

HUNTER DOUGLAS EUROPE B.V.

2, Piekstraat

P.O. Box 5072 - 3008 AB Rotterdam

Tel. 010-4869911 - Fax 010-4847910

luxalon@hde.nl - www.luxalon.com

HunterDouglas®

Hunter Douglas is the world market leader in window covering and a major manufacturer of Architectural Products. The group, which origin goes back to 1919, is comprised over 150 companies with manufacturing and assembly organizations in more than 100 countries.

© Registered trademark - a HunterDouglas® product Pats. & Pats. Pend. - Technical data subject to change without notice.
© Copyright Hunter Douglas 2005. No rights can be derived from copy, text pertaining to illustrations or samples. Subject to changes in materials, parts, compositions, designs, versions, colours etc., even without notice. MX555S00

